

TFT LCD Specification

Model NO.: TD035STED4

Table of Contents

NO.	Item	Page
	Cover Sheet	1
	Table of Contents	2
	Record of Reversion	3
1	Features	4
2	General Specification	4
3	Input / Output Terminals	5
4	Absolute Maximum Ratings	9
5	Electrical Characteristics	10
6	Block Diagram	12
7	Timing Chart	13
8	Power On/Off Sequence	17
9	Optical Characteristics	18
10	Reliability	22
11	Handling Cautions	23
12	Application Note	24
13	Mechanical Drawing	33
14	Packing Drawing	36

Record of Reversion

Rev	Issued Date	Description
1.0	Aug, 15,2005	New

1. FEATURES

The 3.5" LCD module is the Transflective active matrix color TFT LCD module. LTPS (Low Temperature Poly Silicon) TFT technology is used and it's COG design. The LCD module includes touch panel, backlight and TFT LCD panel with minimal external circuits and components required.

2. GENERAL SPECIFICATION

Item		Description	Unit
Display Size (Diagonal)		3.5 inch (8.9cm)	-
Display Type		Transflective	-
Active Area (HxV)		53.28 X 71.04	mm
Number of Dots (HxV)		240 x RGB x 320	dot
Dot Pitch (HxV)		0.074 X 0.222	mm
Color Arrangement		RGB Stripe	-
Color Numbers		262,144 (6 bits)	-
Outline Dimension (HxVxT)		64.3 X 87.1X4.1(Max 4.3)*	mm
Weight		45	g
Power consumption	LCD Panel + T-CON + L/S	25 (Typ)	mW
	Backlight	288 (Typ, I _F = 20mA)	

* Exclude FPC and protrusions.

3. INPUT/OUTPUT TERMINALS

3.1 TFT LCD module

Pin	Symbol	I/O	Description	Remark
1	DE	I	Data Enable Signal	
2	MCLK	I	LCM Pixel Clock	
3	RESET	I	Reset Signal	
4	YU	O	Upper electrode Y (Y+)	
5	DVSS	I	Digital Ground	
6	VCOM_I	I	VCOM Signal Input for LCD Panel	
7	VCOM_I	I	VCOM Signal Input for LCD Panel	
8	AVSS	I	Analog Ground	
9	VVEE	I	Input Voltage for gate off	
10	VVEE	I	Input Voltage for gate off	
11	VGH	I	Input Voltage for Level Shifter I/O	
12	VGH	I	Input Voltage for Level Shifter I/O	
13	DVSS	I	Digital Ground	
14	XL	O	Lower electrode X (X-)	
15	VCOM_H	O	Positive Power Output for VCOM	Connect big capacitor (10uF)
16	VCOM_O	O	VCOM Signal of IC Output	
17	VCOM_O	O	VCOM Signal of IC Output	
18	VCOM_L	O	Negative Power Output for VCOM	Connect big capacitor (10uF)
19	AVSS	I	Analog Ground	
20	DVDD	I	Digital Supply Power	
21	DVDD	I	Digital Supply Power	
22	AVDD	I	Analog Supply Power	
23	AVDD	I	Analog Supply Power	
24	YL	O	Lower electrode Y (Y-)	
25	DVSS	I	Digital Ground	
26	IV6P	O	Not connect this pin	
27	XR	O	Upper electrode X (X+)	
28	TB_RL	I	Shift direction (Right/Left) H: D1→ D240 L: D240→ D1 Shift direction (Top/Bottom) H: Top→ Bottom L: Bottom→ Top	
29	R5	I	Data Bit Input (Red MSB)	
30	R4	I	Data Bit Input	

31	R3	I	Data Bit Input	
32	R2	I	Data Bit Input	
33	R1	I	Data Bit Input	
34	R0	I	Data Bit Input (Red LSB)	
35	G5	I	Data Bit Input (Green MSB)	
36	G4	I	Data Bit Input	
37	G3	I	Data Bit Input	
38	G2	I	Data Bit Input	
39	G1	I	Data Bit Input	
40	G0	I	Data Bit Input (Green LSB)	
41	B5	I	Data Bit Input (Blue MSB)	
42	B4	I	Data Bit Input	
43	B3	I	Data Bit Input	
44	B2	I	Data Bit Input	
45	B1	I	Data Bit Input	
46	B0	I	Data Bit Input (Blue LSB)	
47	ISC	O	Not connect this pin	
48	SCL	I	Digital Ground (Serial interface clock input)	
49	SDA	I	Digital Ground (Serial interface data input/output)	
50	CS	I	Digital Ground (Serial interface chip select input)	
51	DVSS	I	Digital Ground	
52	HSYNC	I	Horizontal SYNC Input	
53	DVSS	I	Digital Ground	
54	CM	I	Display mode select	CM=L: Full display mode (65k/262k color) CM=H: Partial display mode (8 color)
55	VS	O	Positive Power Output for Source Driver	
56	VSYNC	I	Vertical SYNC Input	
57	LED+	I	LED Power (Anode)	
58	LED+	I	LED Power (Anode)	
59	LED-	O	LED Power (Cathode)	

60	LED-	O	LED Power (Cathode)	
61	DVSS	I	Digital Ground	

3.2 Touch panel Pin

Touch Panel Pin	Module Pin	Symbol	Description	Remark
1	4	YU	Touch Panel Upper Side	
2	27	XR	Touch Panel Right Side	
3	24	YL	Touch Panel Lower Side	
4	14	XL	Touch Panel Left Side	

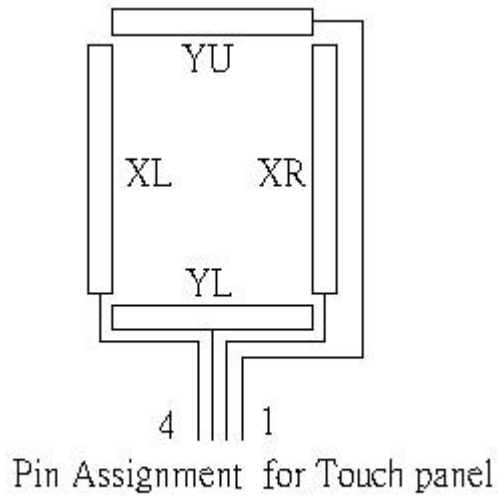

3.3 Back light pin assignment

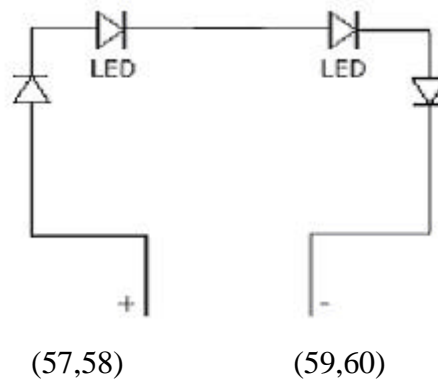

4 ABSOLUTE MAXIMUM RATINGS

GND=0V

Item	Symbol	MIN	MAX	Unit	Remark
Logic Supply Voltage	DVDD	-0.3	+3.6	V	
	AVDD	-0.3	6	V	
Power Supply for H/V Driver	VGH	-0.3	+19	V	
	VVEE	-5.8	-5.2	V	Note 1
Touch Panel Operation Voltage	V_{Touch}	-	5.5	V	
Backlight LED forward Voltage	V_F	-	4	V	
Backlight LED reverse Voltage	V_R	-	5	V	
Backlight LED forward current (Ta=25°C)	I_F	-	30	mA	Note2
Operating Temperature	Topr	-10	+60	°C	
Storage Temperature	Tstg	-20	+70	°C	

Note1. The operating voltage is between +0.5V and -5.0V at the moment when the power is turned on

Note 2. Relation between maximum LED forward current and ambient temperature is showed as bellow.

■ Ambient Temperature vs. Allowable Forward Current

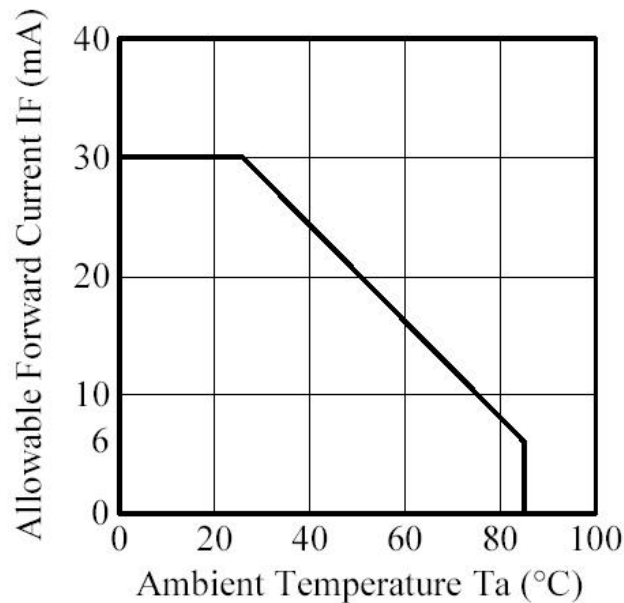

5 ELECTRICAL CHARACTERISTICS

5.1 Driving TFT LCD Panel

T a=25°C

Item	Symbol	MIN	TYP	MAX	Unit	Remark
Logic Supply Voltage	DVDD	2.4	2.8	3.3	V	
	AVDD	4.8	5	5.6	V	
Power Supply for H/V Driver	VGH	9.5	10	10.5	V	
	VVEE	-5.8	-5.5	-5.2	V	
Logic Input Voltage	High	VIH	0.8DVDD	—	DVDD+0.3	R[5:0], G[5:0], B[5:0], CLK DE
	Low	VIL	DVSS	—	0.2DVDD	
Leakage current	IL	-1	—	1	uA	
DVDD Supply Current	I _{DVDD}	-	0.74	1.9	mA	Note 1,2
AVDD Supply Current	I _{AVDD}	-	1.65	4.0	mA	Note 3
VGH Supply Current	I _{VGH}	-	0.07	0.2	mA	
VVEE Supply Current	I _{VVEE}	-	0.05	0.5	mA	

Note 1: The typical supply current specification is measured at the line inversion test pattern (black and white interlacing horizontal lines as the diagram shown below)



Note 2: DVDD rush current accept 120mA, 500u sec during system booting.

Note 3: Gamma correction voltage is set to achieve the optimum at AVDD=5.0V. Use the voltage at level as close to 5.0V as possible.

5.2 DC/DC Spec

Item	Input voltage			Input Current	Input ripple(Max)	
	MIN	TYP	MAX			
DVDD	2.4V	2.8V	3.3V	0.74	--	
AVDD	4.8V	5V	5.6V	1.65	50 mV	Note 1
VGH	9.5V	10V	10.5V	0.07	150mV	
VVEE	-5.8 V	-5.5 V	-5.2 V	0.05	--	

Note 1: AVDD is analog voltage supply therefore use as less ripple as possible.

5.3 Driving backlight

Ta=25°C

Item	Symbol	MIN	TYP	MAX	Unit	Remark
Forward Current	I _F	-	20	30	mA	LED/Part
LED Life Time			5,000		Hr	I _F : 20mA
			10,000		Hr	I _F : 15mA
Forward Current Voltage	V _F	-	3.6	4.0	V	I _F : 20mA ,LED/Part

Note: Backlight driving circuit is recommend as the fix current circuit.

5.4 Driving touch panel (Analog resistance type)

Ta=25°C

Item	Symbol	MIN	TYP	MAX	Unit	Remark
Resistor between terminals (XR-XL)	R _x	100	-	1100	Ω	
Resistor between terminals (YU-YL)	R _y	100	-	1100	Ω	
Operation Voltage	V _{Touch}	-	5	-	V	DC
Line Linearity (X direction)	-	-1.5	-	+1.5	%	Note 1
Line Linearity (Y direction)	-	-1.5	-	+1.5	%	
Chattering	-	-	-	10	ms	
Minimum tension for detecting	-	-	-	80-	g	
Insulation Resistance	R _i	20	-	-	MΩ	At DC 25V

Note 1. The minimum test force is 80 g.

6 BLOCK DIAGRAM

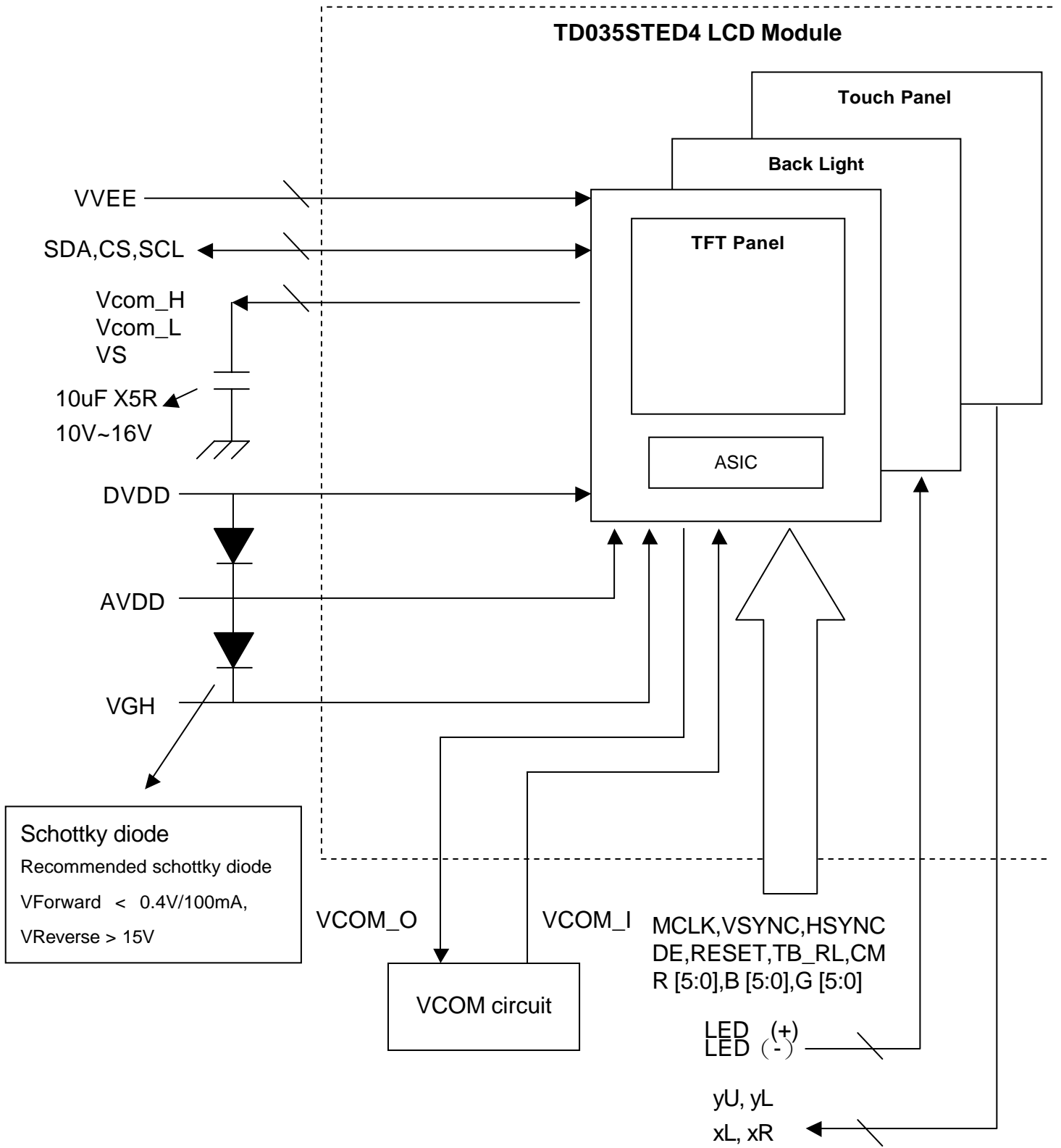

7 TIMING CHART

7.1 Display timing

Display Mode	Parameter	Symbol	Conditions	Ratings			Unit
				MIN	TYP	MAX	
Normal	Vertical cycle	VP		323	326	340	Line
	Vertical data start	VDS	VS+VBP	2	4	—	Line
	Vertical front porch	VFP		1	2	—	Line
	Vertical blanking period	VBL	VS+VBP+VFP	3	6	—	Line
	Vertical active area	VDISP		—	320	—	Line
	Horizontal cycle	HP		260	280	300	dot
	Horizontal front porch	HFP		4	10	—	dot
	Horizontal Sync Pulse width	HS		8	10	—	dot
	Horizontal Back porch	HBP		18	20	—	dot
	Horizontal Data start	HDS	HS+HBP	26	30	—	dot
	Horizontal active area	HDISP		240	240	240	dot
	Clock frequency	fclk			5.02	6.39	6.85
tclk				199	156	146	nS

Input timing chart

< Vertical Timing chart >

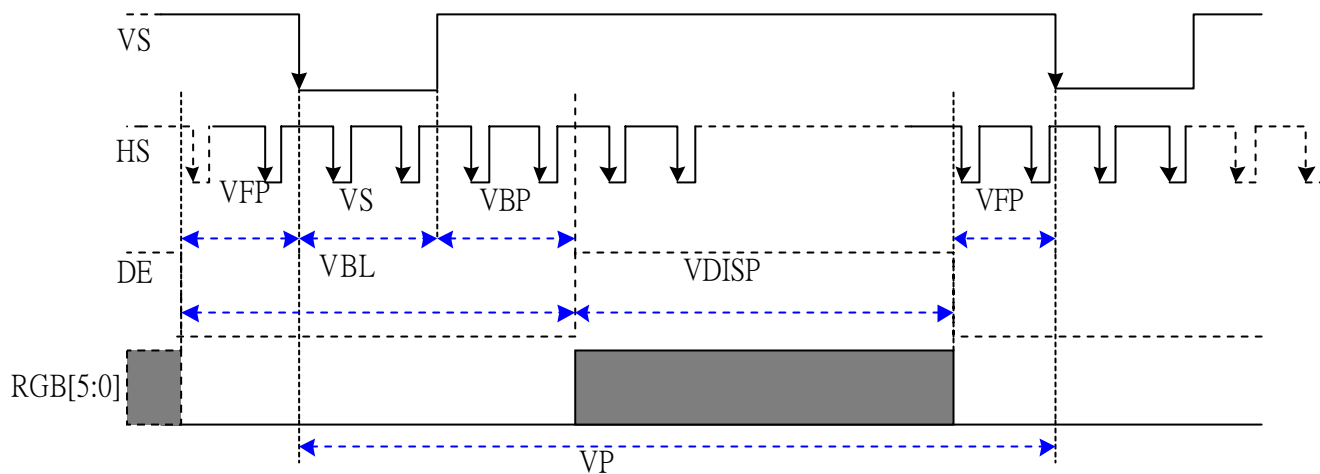

< Horizontal Timing chart >

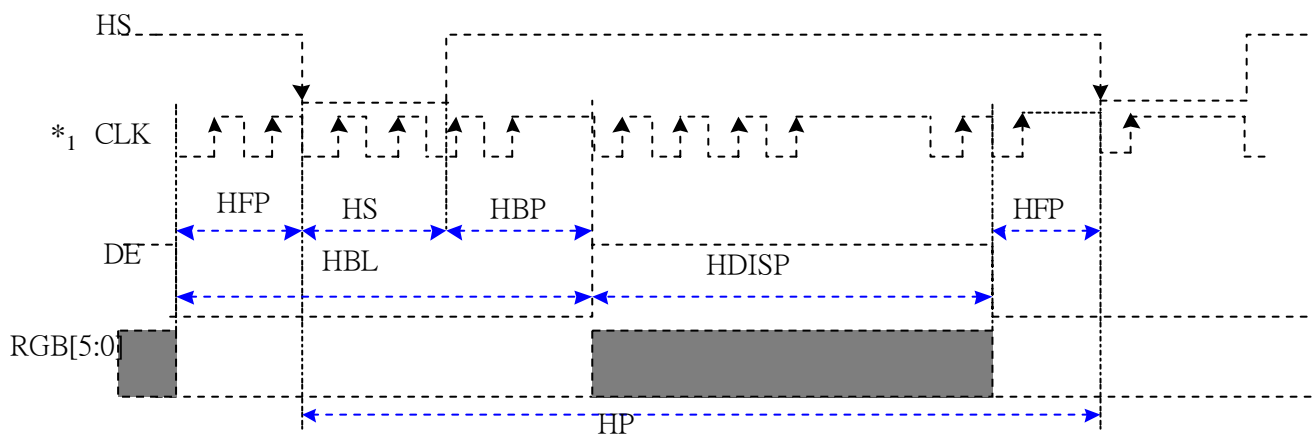

*₁. The frequency of CLK should be continued whether in display or blank region to ensure IC operating normally.

Setup/ Hold Timing chart

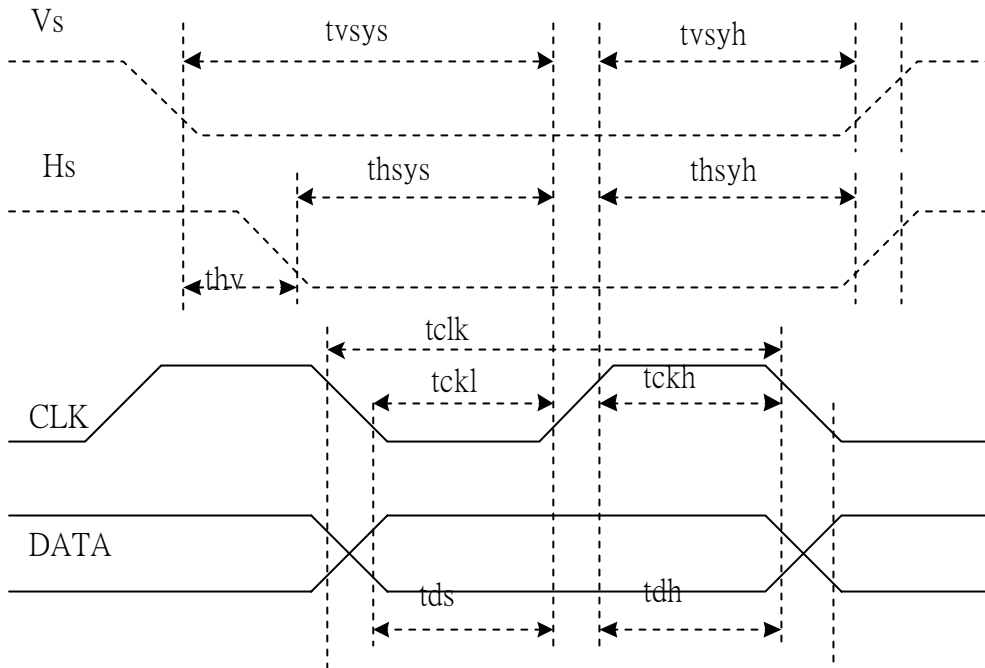

Phase difference of Sync.

Maximum Timing chart :

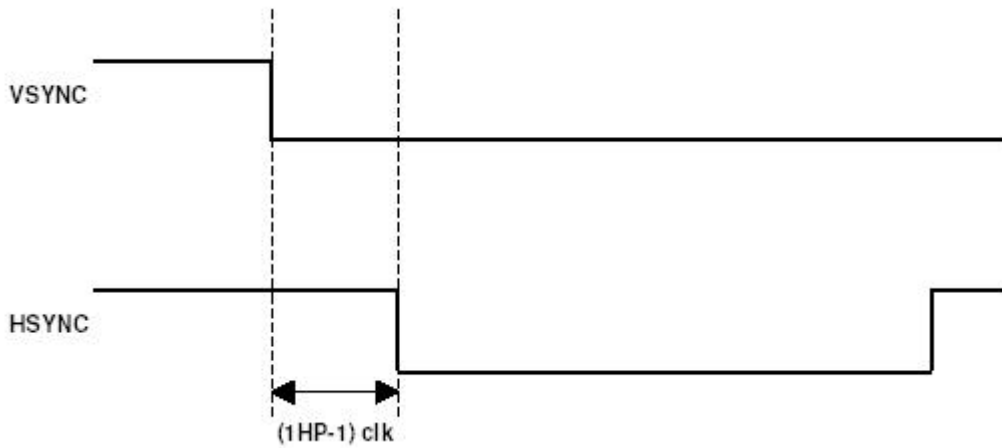

Minimum Timing chart:

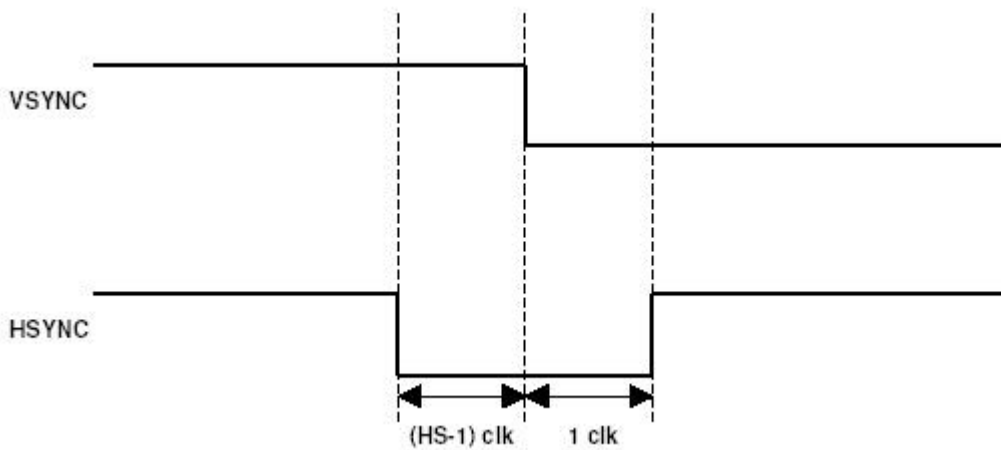

AC Characteristics:

Parameter	Symbol	Conditions	Ratings			Unit
			MIN	TYP	MAX	
Vertical Sync. Setup time	tvsys		20	—	—	ns
Vertical Sync. Hold time	tvsyh		20	—	—	ns
Horizontal Sync. Setup time	thsys		20	—	—	ns
Horizontal Sync. Hold time	thsyh		20	—	—	ns
Phase difference of Sync. Signal Falling edge	thv		-(HS-1)	—	1HP-1	clk
Clock "L" Period	tckl		30	50	70	%
Clock "H" Period	tckh		30	50	70	%
Data setup time	tds		20	—	—	ns
Data Hold time	tdh		20	—	—	ns
Digital logic input	Trise/Tfall				15	ns

8 Power On/Off Sequence

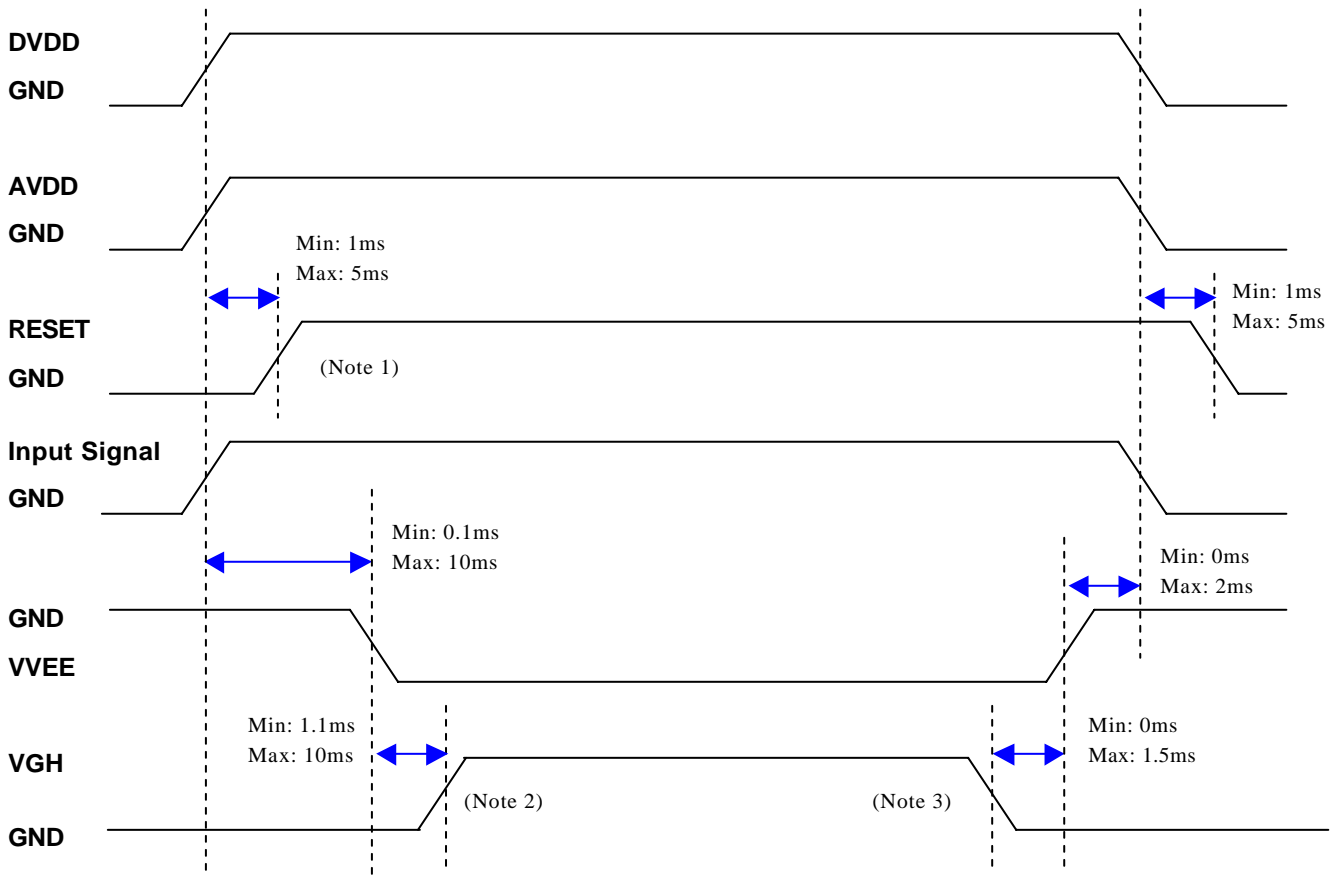

Power on sequence:

DVDD & AVDD & Input signal ϕ RESET ϕ VVEE ϕ VGH

Power off sequence:

VGH ϕ VVEE ϕ DVDD & AVDD & Input signal ϕ RESET

(Note 1) Display start at the 10th falling edge of VSYNC after RESET rising (first 1 frame=white)

(Note 2) VGH will be pulled up to AVDD-0.7V before VGH power on , due to external schottky diode.

(Note 3) To avoid image retention , please input white image for two frame before power off.

9 Optical Characteristics

9.1 Optical Specification

9.1.1 Back light Off w / Touch panel

Ta=25°C

Item	Symbol	Condition	MIN	TYP	MAX	Unit	Remarks	
Viewing Angles	θ 11	CR = 2	45	50	-	Degree	Note 9-1	
	θ 12		25	35	-			
	θ 21		30	40	-			
	θ 22		45	55	-			
Chromaticity	White	$\theta = 0^\circ$	x	0.26	0.31	0.36	-	Note 9-3
			y	0.30	0.35	0.40	-	
Contrast Ratio	CR	$\theta = 0^\circ$	10:1	15:1	-	-	Note 9-2	
Reflectivity	R	$\theta = 0^\circ$	7	10	-	%	Note 9-4	

9.1.2 Back Light On w / Touch panel

Ta=25°C

Item	Symbol	Condition	MIN	TYP	MAX	Unit	Remarks	
Viewing Angles	θ 11	CR = 2	50	60	-	Degree	Note 9-1	
	θ 12		50	60	-			
	θ 21		40	50	-			
	θ 22		50	60	-			
Response Time	Tr+Tf	$\theta = 0^\circ$	-	35	45	ms	Note 9-5	
Contrast Ratio	CR	$\theta = 0^\circ$	80:1	100:1	-	-	Note 9-6	
Luminance	L	$\theta = 0^\circ$ If = 20mA	90	115	-	cd/m ²	Note 9-7	
NTSC	-	-	32	36	-	%	Note 9-7	
Uniformity	-	-	70	80	-	%	Note 9-8	
Chromaticity	White	$\theta = 0^\circ$	x	0.26	0.31	0.36	-	Note 9-3
			y	0.28	0.33	0.38		
	R	$\theta = 0^\circ$	x	0.50	0.55	0.60	-	
			y	0.27	0.32	0.37		
	G	$\theta = 0^\circ$	x	0.29	0.34	0.39	-	
			y	0.28	0.53	0.58		
B	$\theta = 0^\circ$	x	0.10	0.15	0.20	-		
		y	0.09	0.14	0.19			

9.2 . Basic measure condition

9.2.1 Driving voltage

DVDD=2.8V , AVDD=5V , AGH= 10.0V , VVEE=-5.5V

9.2.2 Ambient temperature: Ta=25°C

9.2.3 Testing point: measure in the display center point and the test angle $\theta = 0^\circ$

9.2.4 Testing Facility

Environmental illumination: = 1 Lux

A. System A

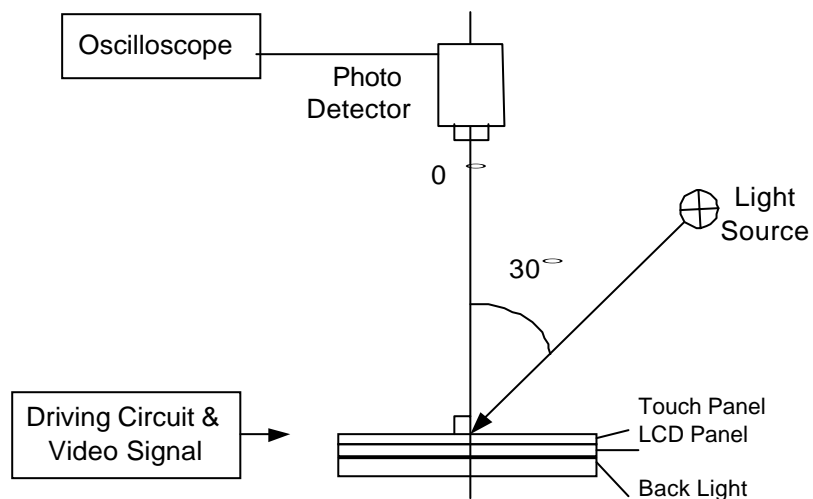

B. System B

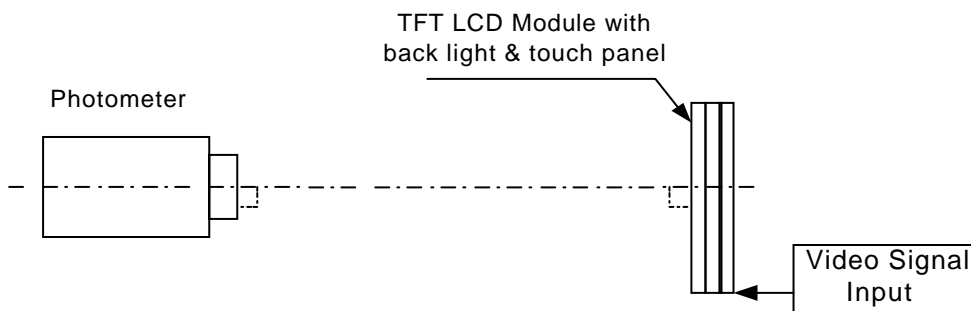

Note 9-1: Viewing angle diagrams (Measure System A)

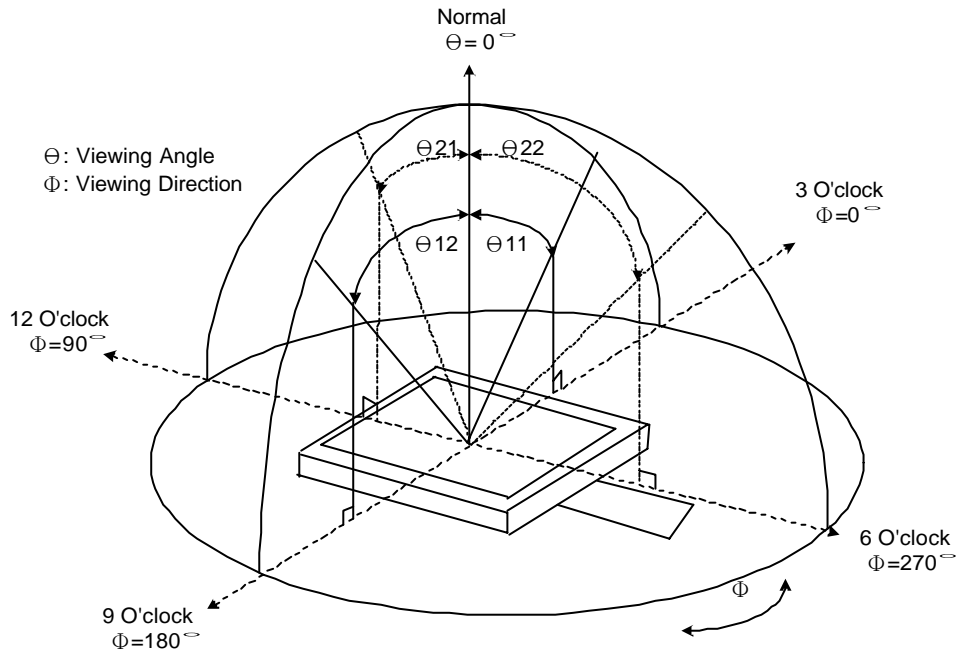

Note 9-2: Contrast ratio in back light off (Measure System A)

Contrast Ratio is measured in optimum common electrode voltage.

$$CR = \frac{\text{Luminance with white image}}{\text{Luminance with black image}}$$

Note 9-3: White chromaticity as back light off: (Measure System A)

Note 9-4: Reflectivity (R) (Measure System A)

In the measuring system A, calculate the reflectance by the following formula.

$$\text{Reflectivity}(R) = \frac{\text{Output from the white display panel}}{\text{Output from the reflectance standard}} \times \text{Reflectance factor of reflectance standard}$$

Note 9-5: Definition of response time: (Measure System B)

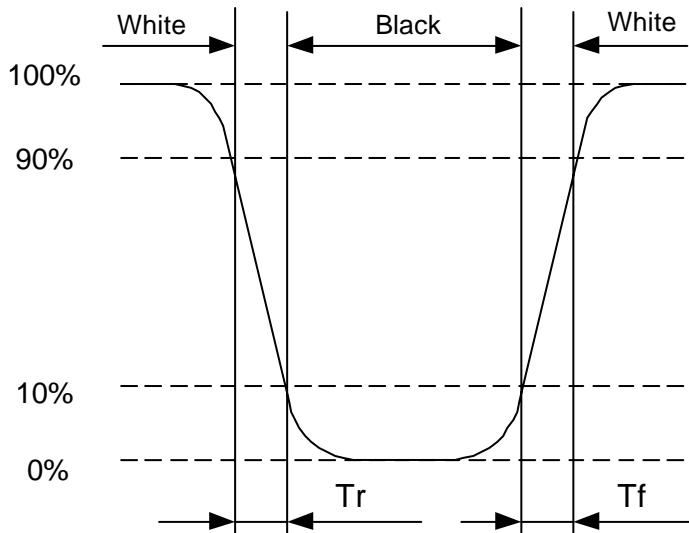

Note 9-6: Contrast Ratio in back light On (Measure System B)

Contrast Ration is measured in optimum common electrode voltage.

$$CR = \frac{\text{Luminance with white image}}{\text{Luminance with black image}}$$

Note 9-7: Luminance: (Measure System B)

Test Point: Display Center

Note 9-8: Uniformity (Measure System B)

The luminance of 9 points as the black dot in the figure shown below are measured and the uniformity is defined as the formula:

$$\text{Uniformity} = \frac{\text{The minimum luminance among 9 points}}{\text{The maximum luminance among 9 points}}$$

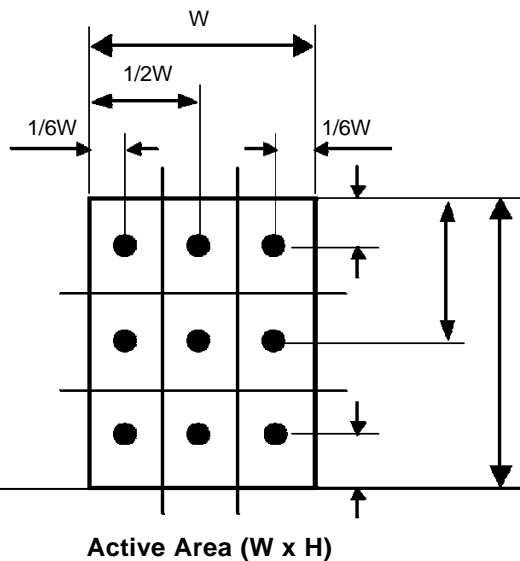

10 Reliability

No	Test Item	Condition
1	High Temperature Operation	Ta=+60°C , 240hrs
2	High Temperature & High Humidity Operation	Ta=+40°C , 95% RH, 240hrs
3	Low Temperature Operation	Ta= -10°C , 240hrs
4	High Temperature Storage (non-operation)	Ta=+70°C , 240hrs
5	Low Temperature Storage (non-operation)	Ta= -20°C , 240hrs
6	Thermal Shock (non-operation)	-20°C (30 min) □ ϕ 70°C (30 min),30 cycles
7	Surface Discharge (non-operation) (LCD surface)	C=150pF, R=330 Ω; Discharge: Air: ±15kV; Contact: ±8kV 10 times / Point; 5 Points / Panel
8	Shock (non-operation)	Acceleration: 100G; Period: 6ms Directions: ±X, ±Y, ±Z; Cycles: Three times
9	Pin Activation Test (Touch Panel)	Hit 1,000,000 times with a silicon rubber of R0.8, HS 60. Hitting Force: 250g Hitting Speed: 3 time/sec
10	Writing Friction Resistance Test (Touch Panel)	Pen: 0.8R Polyacetal stylus Load: 250g Speed: 3 Strokes/sec Stroke: 35mm 100000 times

11 Handling Cautions

11.1 ESD (Electrical Static Discharge) strategy

ESD will cause serious damage of the panel, ESD strategy is very important in handling. Following items are the recommended ESD strategy

11.1.1 In handling LCD panel, please wear gloves with non-charged material. Using the conduction ring connect wrist to the earth and the conducting shoes to the earth is necessary.

11.1.2 The machine and working table for the panel should have ESD protection strategy.

11.1.3 In handling the panel, ionized air flowing decrease the charge in the environment is necessary.

11.1.4 In the process of assemble the module, shield case should connect to the ground.

11.2 Environment

11.2.1 Working environment should be clean room.

11.2.2 Because touch panel has protective film on the surface, please remove the protection film slowly with ionizer to prevent the electrostatic discharge.

11.3 Touch panel

11.3.1 The front touch panel is vulnerable to heavy weight, so any input must be done by special stylus or by a finger. Do not put any heavy stuff on it.

11.3.2 When any dust or stain is observed on a film surface, clean it using a lens cleaner for glasses or something similar.

11.4 Others

11.4.1 Turn off the power supply before connecting and disconnecting signal input cable.

11.4.2 Because the connection area of FPC and panel is not so strong, do not handle panel only by FPC or bend FPC.

11.4.3 Water drop on the surface when panel is powered on will corrode panel electrode.

11.4.4 Before opening up the packing bag, watch out the environment for the panel storage. High temperature and high humidity environment is prohibited.

11.4.5 In the case the TFT LCD module is broken, please watch out whether liquid crystal leaks out or not. If your hand touches liquid crystal, wash your hands cleanly with water and soap as soon as possible

12 Application Note

12.1 Design notes on touch panel

12.1.1 Explanation of each boundary of touch panel

A. Boundary of Double-sided adhesive

- a. Electrically detectable within this zone.

When holding the touch panel by housing, it needs to be held at outside of this zone.

- b. Film is supported by double-sided adhesive tape.

B. Viewing area

- a. Cosmetic inspection to be done for this area.

This area is set as inside of boundary of double-sided adhesive with tolerance. C.

Boundary of transparent insulation

- a. Purpose is to "Help" to secure insulation.

- b. Electrical insulation on this area is not guaranteed.

- c. We do recommend not to hold this area by something like housing or gasket.

D. Active area

- a. This area is where the performance is guaranteed.

This area set as some distance inside from the boundary area of double-sided adhesive tape since its neighboring area is less durable to writing friction.

- b. Please refer to the attached module drawing for the bezel opening and window size design.

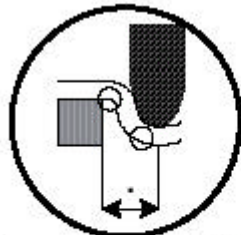

There is some possibility
to damage ITO

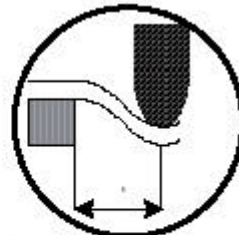

No Damage to ITO

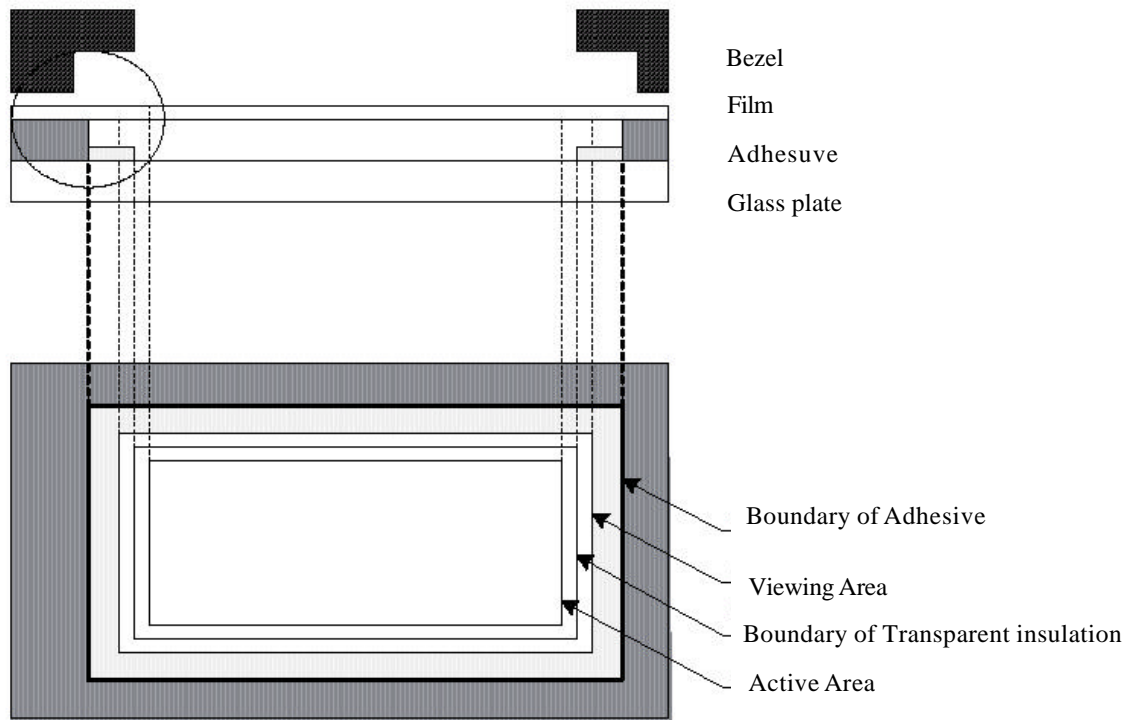

12.1.2 Housing and touch panel

- A. Please have clearance between the side of touch panel, and any conductive material such as metal frame.(drawing.1) Transparent electrode exists on glass of touch panel from end to end.
- B. It is recommended to fix a touch panel on the LCD module chassis rather than the touch panel housing. Clinging at conductive material and side of touch panel might cause malfunction.

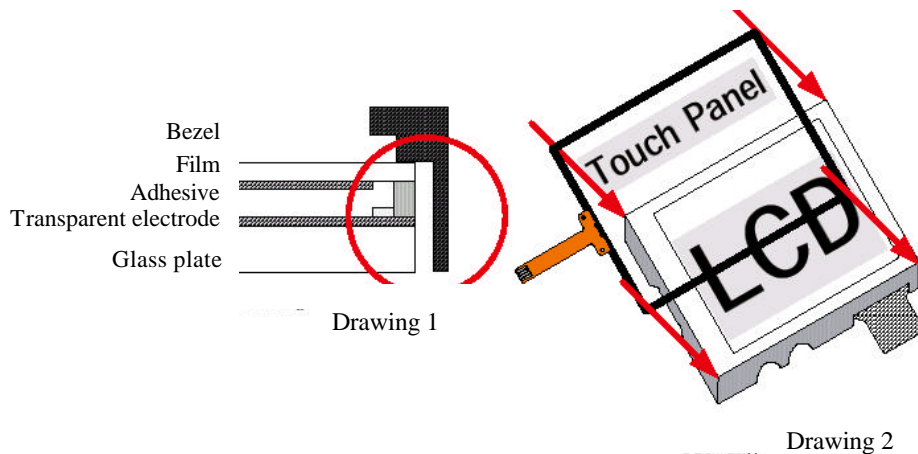

12.2 Note for V-com circuit

The circuit is designed for Vcom fine-tune, please refer the circuit below to design application circuit.

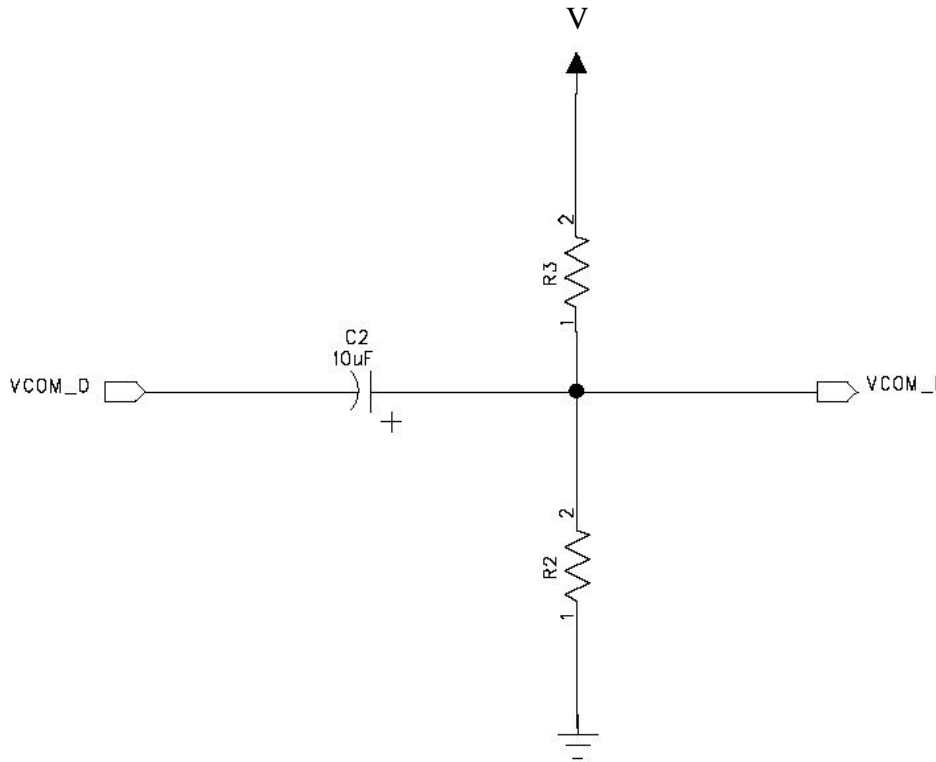

Vcom waveform

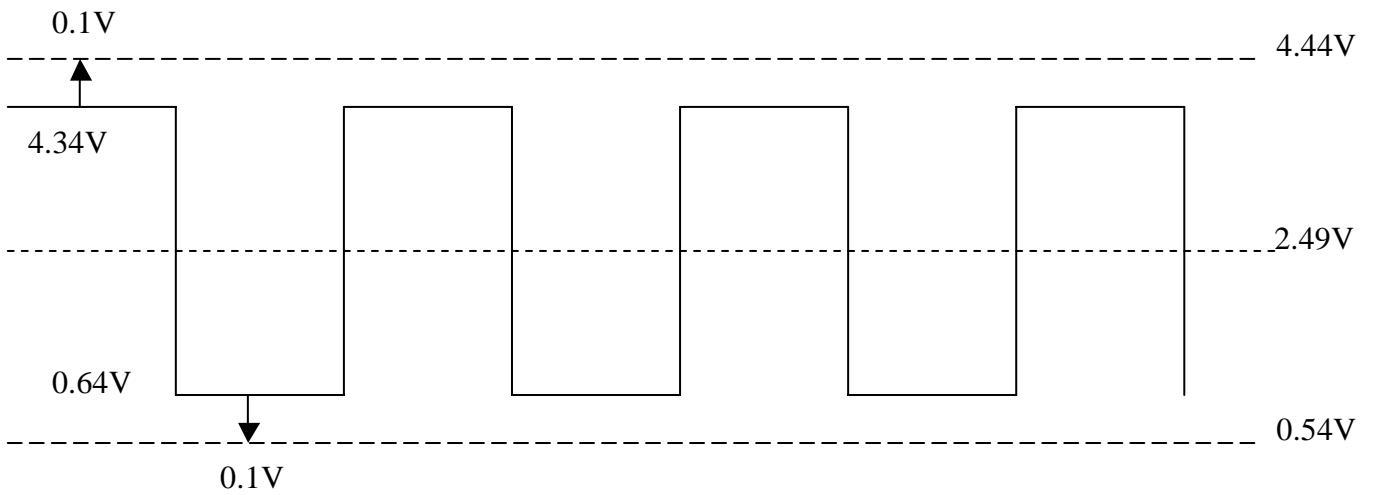

Note:

V : 5 V

R2 : 10~20 K Ohm

R3 : 10~20 K Ohm

Resistors tolerance : 0.5~1 %

12.3 Note for SPI command

The LCM support the 3-pin serial interface to set internal register. Read/Write bit RW, Serial address A6 to A0 and serial data D7 to D0 are read at the rising edge of the serial clock, via the serial input pin. This data is synchronized on the rising edge of eighth serial clock and is then converted to parallel data. The serial interface signal timing chart is shown below.

Serial Interface Signal Timing Chart

Write Mode (RW=L)

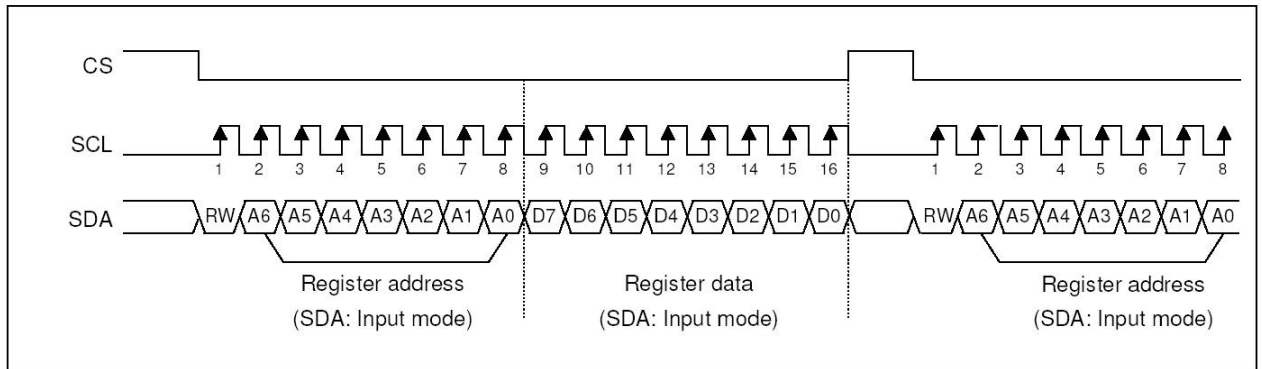

The shift register and counter are reset to their initial values when the chip select signal is inactive. Do not set the chip select signal to inactive between transmission of an 8-bit address and 8-bit data set for the command.

When using SCL wiring, the module has to be designed carefully to avoid any noise coming from reflection or from external sources. We recommend checking operation with the actual module.

If there is a break in data transmission by RESETB or CS pulse, while transferring a Command or Parameter, before Bit D0 of the byte has been completed, then LCM will reject the previous bits and have reset the interface such that it will be ready to receive the same byte re-transmitted when the chip select line (CS) is activated after RESETB have been High state.

Read Mode (RW=H)

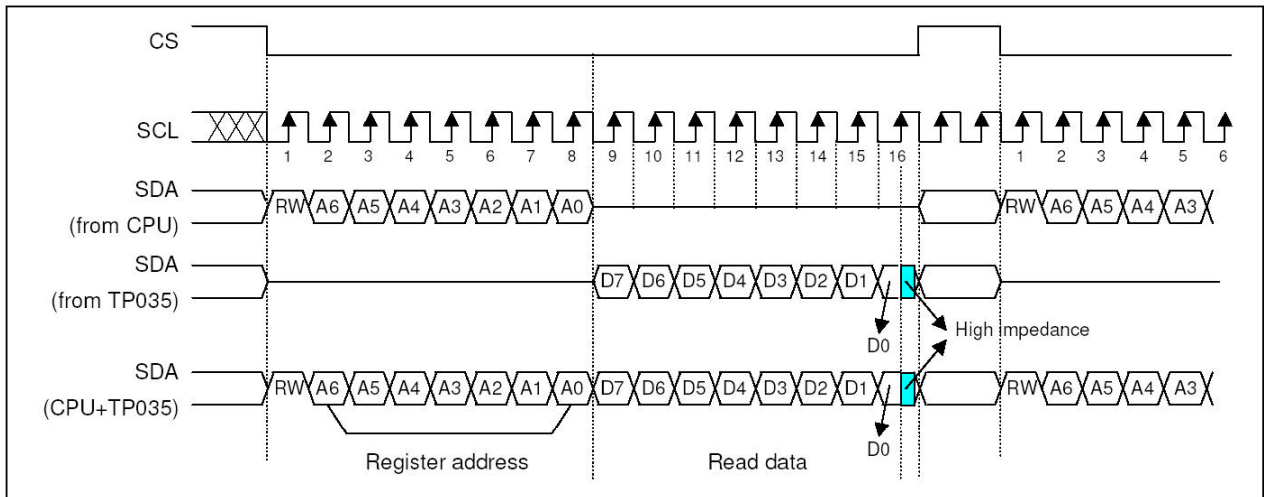

The read mode of the interface means that the micro controller reads data from the LCM. To do so the micro controller first has to send a command: the read status command. Then the following byte is transmitted in the opposite direction. After that CS is required to go high.

The LCM samples the SDA data input at rising SCL edges, but shifts SDA data output at falling SCL edges. Thus the micro controller is supposed to read SDA data at rising SCL edges.

After the read status command has been sent, the SDA line must be set to tristate not later then at the rising SCL edge of the last bit.

The LCM can read data of the Register0 to Register63

Serial interface and Reset waveform (VIH=0.8VDD1, VIL=0.2VDD1)

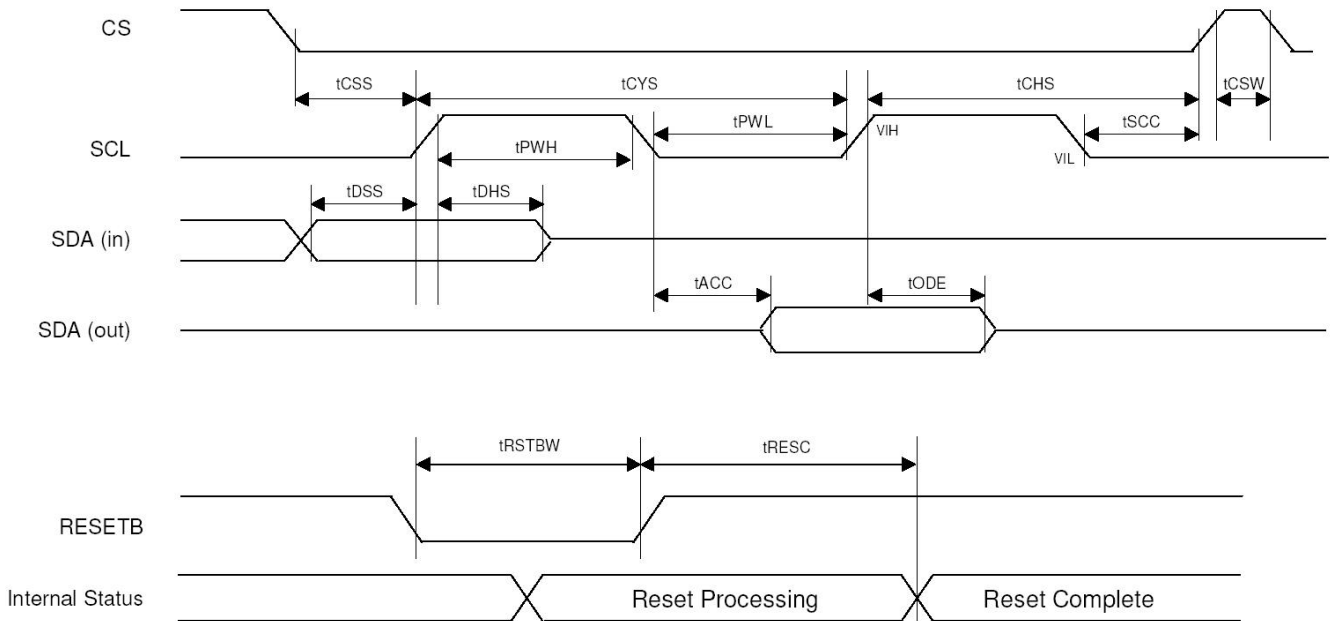

Serial interface and Reset						
Parameter	Symbol	Conditions	Min.	Typ.	Max.	Unit
Clock cycle	tCYS	-	150	-	-	ns
Clock High Period	tPWH	-	60	-	-	ns
Clock Low Period	tPWL	-	60	-	-	ns
Data Set-up Time	tDSS	-	60	-	-	ns
Data Hold Time	tDHS	-	60	-	-	ns
CS High width	tCSW	-	1	-	-	us
CS Set-up Time	tCSS	-	60	-	-	ns
CS Hold Time	tCHS	-	70	-	-	ns
SCL to CS	tSCC	-	40	-	-	ns
Output Access Time	tACC	-	10	-	50	ns
Output Disable Time	tODE	-	25	-	80	ns
RSTB low width	tRSTBW	-	1000	-	-	ns
RESET complete time	tRESC	-	-	-	1000	ns

Command descriptions :

Reset the internal register by setting low level the RESETB pin or software reset command.

Register [Dec]	Default [Hex]	Bit name	Setting value							Description	Remark		
			D7	D6	D5	D4	D3	D2	D1			D0	
R0	00h	CHIPID[2:0]								Chip ID (Read only)	The Chip ID can be changed by MASK Option.		
			0 0 0							ID 0(LDS312A)			
			0 0 1							ID 1(LDS312B)			
			-							-			
			1 1 0							ID 6			
			1 1 1							ID 7			
		REVID[2:0]								Revision ID (Read only)	The Revision ID can be changed by MASK Option.		
			0 0 0							REV 0			
			0 0 1							REV 1			
			-							-			
			1 0 1							REV 5(F)			
			1 1 0							REV 6			
			1 1 1							REV 7			
R1	68h	VCM8[7:5]								VCOM amplitude adjustment by VCOMH voltage change	VCOMH voltage change		
			0 0 0							-0.3V			
			0 0 1							-0.2V			
			0 1 0							-0.1V			
			0 1 1							0.0V			
			1 0 0							0.1V			
			1 0 1							0.2V			
			1 1 0							0.3V			
			1 1 1							0.4V			
			VCM8[3:0]									VCOM voltage select	VCOM_DC value setting
				0 0 0 0								VCOMH=3.90V ; VCOML=0.20V	
				0 0 0 1								VCOMH=3.92V ; VCOML=0.22V	
				0 0 1 0								VCOMH=3.94V ; VCOML=0.24V	
		0 0 1 1							VCOMH=3.96V ; VCOML=0.26V				
		0 1 0 0							VCOMH=3.98V ; VCOML=0.28V				
		0 1 0 1							VCOMH=4.00V ; VCOML=0.30V				
		0 1 1 0							VCOMH=4.02V ; VCOML=0.32V				
		0 1 1 1							VCOMH=4.04V ; VCOML=0.34V				
		1 0 0 0							VCOMH=4.06V ; VCOML=0.36V				
		1 0 0 1							VCOMH=4.08V ; VCOML=0.38V				
		1 0 1 0							VCOMH=4.10V ; VCOML=0.40V				
		1 0 1 1							VCOMH=4.12V ; VCOML=0.42V				
		1 1 0 0							VCOMH=4.14V ; VCOML=0.44V				
		1 1 0 1							VCOMH=4.16V ; VCOML=0.46V				
		1 1 1 0							VCOMH=4.18V ; VCOML=0.48V				
		1 1 1 1							VCOMH=4.20V ; VCOML=0.50V				
		R2	00h	MSEL								Interface mode select	Mode selection
					0							VSYNC + HSYNC + DE mode	
					1							VSYNC + HSYNC mode	
				SYNCP								SYNC polarity select	
0							Negative						
1							Positive						
DINT								Input data mapping select					
	0							18 bit interface (262k color)					
1							16 bit interface (65k color, R:G:B=5:6:5)						
DCKP								Input clock polarity change					
	0							No change					
1							Change						
R3	04h	VSTS[3:0]								Vertical valid data start time select (VBP)	Default: QVGA = 4 HSYNC QCIF+ = 7 HSYNC 128x160 = 13 HSYNC 240x240 = 4 HSYNC		
			0 0 0 0							2 HSYNC			
			0 0 0 1							2 HSYNC			
			0 0 1 0							2 HSYNC			
			0 0 1 1							3 HSYNC			
			0 1 0 0							4 HSYNC			
			0 1 0 1							5 HSYNC			
			-							-			
			1 1 1 1							15 HSYNC			

Register [Dec]	Default [Hex]	Bit name	Setting value								Description	Remark
			D7	D6	D5	D4	D3	D2	D1	D0		
R4	1Dh	HSTS[5:0]									Horizontal valid data start time select (HBP)	Default: QVGA = 30 DCK QCIF+ = 44 DCK 128x160 = 36 DCK 240x240 = 30 DCK
					0	0	0	0	0	0	10 DCK	
					0	0	0	0	0	0	10 DCK	
					0	0	0	0	0	1	10 DCK	
					0	0	0	0	0	1	10 DCK	
					0	0	0	0	1	1	10 DCK	
					0	0	0	1	0	0	10 DCK	
					0	0	0	1	0	1	10 DCK	
					0	0	0	1	1	0	10 DCK	
					0	0	0	1	1	1	10 DCK	
					0	0	1	0	0	0	10 DCK	
					0	0	1	0	0	1	10 DCK	
					0	0	1	0	1	0	11 DCK	
					0	0	1	1	0	0	12 DCK	
					-	-	-	-	-	-	-	
					0	1	1	1	1	0	30 DCK	
		-	-	-	-	-	-	-				
		1	1	1	1	1	1	63 DCK				
R5	01h	PARS[7:0]								Partial start line select	When VSYNC+HSYNC+DE mode, DE=H: Normal display line DE=L: Non-display line (White) When VSYNC+HSYNC mode, Normal display line can be selected by R5,6,7 and 8.	
			0	0	0	0	0	0	0	0		Do not setting when PARS[8]=0, Gate256 is selected when PARS[8]=1
			0	0	0	0	0	0	0	1		Gate1 is selected when PARS[8]=0, Gate257 is selected when PARS[8]=1
			0	0	0	0	0	0	1	0		Gate2 is selected when PARS[8]=0, Gate258 is selected when PARS[8]=1
			0	0	0	0	0	0	1	1		Gate3 is selected when PARS[8]=0, Gate259 is selected when PARS[8]=1
			-	-	-	-	-	-	-	-		-
			0	0	1	1	1	1	1	1		Gate63 is selected when PARS[8]=0, Gate319 is selected when PARS[8]=1
			0	1	0	0	0	0	0	0		Gate64 is selected when PARS[8]=0, Gate320 is selected when PARS[8]=1
			0	1	0	0	0	0	0	1		Gate65 is selected when PARS[8]=0, Do not setting when PARS[8]=1
			0	1	0	0	0	0	1	0		Gate66 is selected when PARS[8]=0, Do not setting when PARS[8]=1
			-	-	-	-	-	-	-	-		-
			1	1	1	1	1	1	1	1		Gate127 is selected when PARS[8]=0, Do not setting when PARS[8]=1
			1	0	0	0	0	0	0	0		Gate128 is selected when PARS[8]=0, Do not setting when PARS[8]=1
			1	0	0	0	0	0	0	1		Gate129 is selected when PARS[8]=0, Do not setting when PARS[8]=1
			1	0	0	0	0	0	1	0		Gate130 is selected when PARS[8]=0, Do not setting when PARS[8]=1
			-	-	-	-	-	-	-	-		-
1	1	1	1	1	1	0	0	Gate252 is selected when PARS[8]=0, Do not setting when PARS[8]=1				
1	1	1	1	1	1	0	1	Gate253 is selected when PARS[8]=0, Do not setting when PARS[8]=1				
1	1	1	1	1	1	1	0	Gate254 is selected when PARS[8]=0, Do not setting when PARS[8]=1				
1	1	1	1	1	1	1	1	Gate255 is selected when PARS[8]=0, Do not setting when PARS[8]=1				
R6	00h	PARS[8]								Partial start line select		
									0	Gate1 – Gate255 is selected		
									1	Gate256 – Gate320 is selected		
R7	20h	PARE[7:0]								Partial end line select	When VSYNC+HSYNC+DE mode, DE=H: Normal display line DE=L: Non-display line (White) When VSYNC+HSYNC mode, Normal display line can be selected by R5,6,7 and 8.	
			0	0	0	0	0	0	0	0		Do not setting when PARE[8]=0, Gate256 is selected when PARE[8]=1
			0	0	0	0	0	0	0	1		Gate1 is selected when PARE[8]=0, Gate257 is selected when PARE[8]=1
			0	0	0	0	0	0	1	0		Gate2 is selected when PARE[8]=0, Gate258 is selected when PARE[8]=1
			0	0	0	0	0	0	1	1		Gate3 is selected when PARE[8]=0, Gate259 is selected when PARE[8]=1
			-	-	-	-	-	-	-	-		-
			0	0	0	1	1	1	1	1		Gate31 is selected when PARE[8]=0, Gate286 is selected when PARE[8]=1
			0	0	1	0	0	0	0	0		Gate32 is selected when PARE[8]=0, Gate287 is selected when PARE[8]=1
			0	0	1	0	0	0	0	1		Gate33 is selected when PARE[8]=0, Gate288 is selected when PARE[8]=1
			0	0	1	0	0	0	1	0		Gate34 is selected when PARE[8]=0, Gate289 is selected when PARE[8]=1
			-	-	-	-	-	-	-	-		-
			1	0	1	1	1	1	1	0		Gate63 is selected when PARE[8]=0, Do not setting when PARE[8]=1
			1	0	1	1	1	1	1	1		Gate64 is selected when PARE[8]=0, Do not setting when PARE[8]=1
			1	1	0	0	0	0	0	0		Gate65 is selected when PARE[8]=0, Do not setting when PARE[8]=1
			1	1	0	0	0	0	0	1		Gate66 is selected when PARE[8]=0, Do not setting when PARE[8]=1
			-	-	-	-	-	-	-	-		-
1	1	1	1	1	1	0	0	Gate252 is selected when PARE[8]=0, Do not setting when PARE[8]=1				
1	1	1	1	1	1	0	1	Gate253 is selected when PARE[8]=0, Do not setting when PARE[8]=1				
1	1	1	1	1	1	1	0	Gate254 is selected when PARE[8]=0, Do not setting when PARE[8]=1				
1	1	1	1	1	1	1	1	Gate255 is selected when PARE[8]=0, Do not setting when PARE[8]=1				
R8	00h	PARE[8]								Partial end line select		
									0	Gate1 – Gate255 is selected		
									1	Gate256 – Gate320 is selected		

Register [Dec]	Default [Hex]	Bit name	Setting value								Description	Remark
			D7	D6	D5	D4	D3	D2	D1	D0		
R10	00h	CMDR									Software reset	
										0	Normal	
										1	Software reset	
R11	67h	VCM8[7:5]									VCOM amplitude adjustment by VCOMH voltage change	VCOMH voltage change (8 color partial mode)
			0	0	0						-0.3V	
			0	0	1						-0.2V	
			0	1	0						-0.1V	
			0	1	1						0.0V	
			1	0	0						0.1V	
			1	0	1						0.2V	
			1	1	0						0.3V	
			1	1	1						0.4V	

12.4 Notes for FPC circuit layout

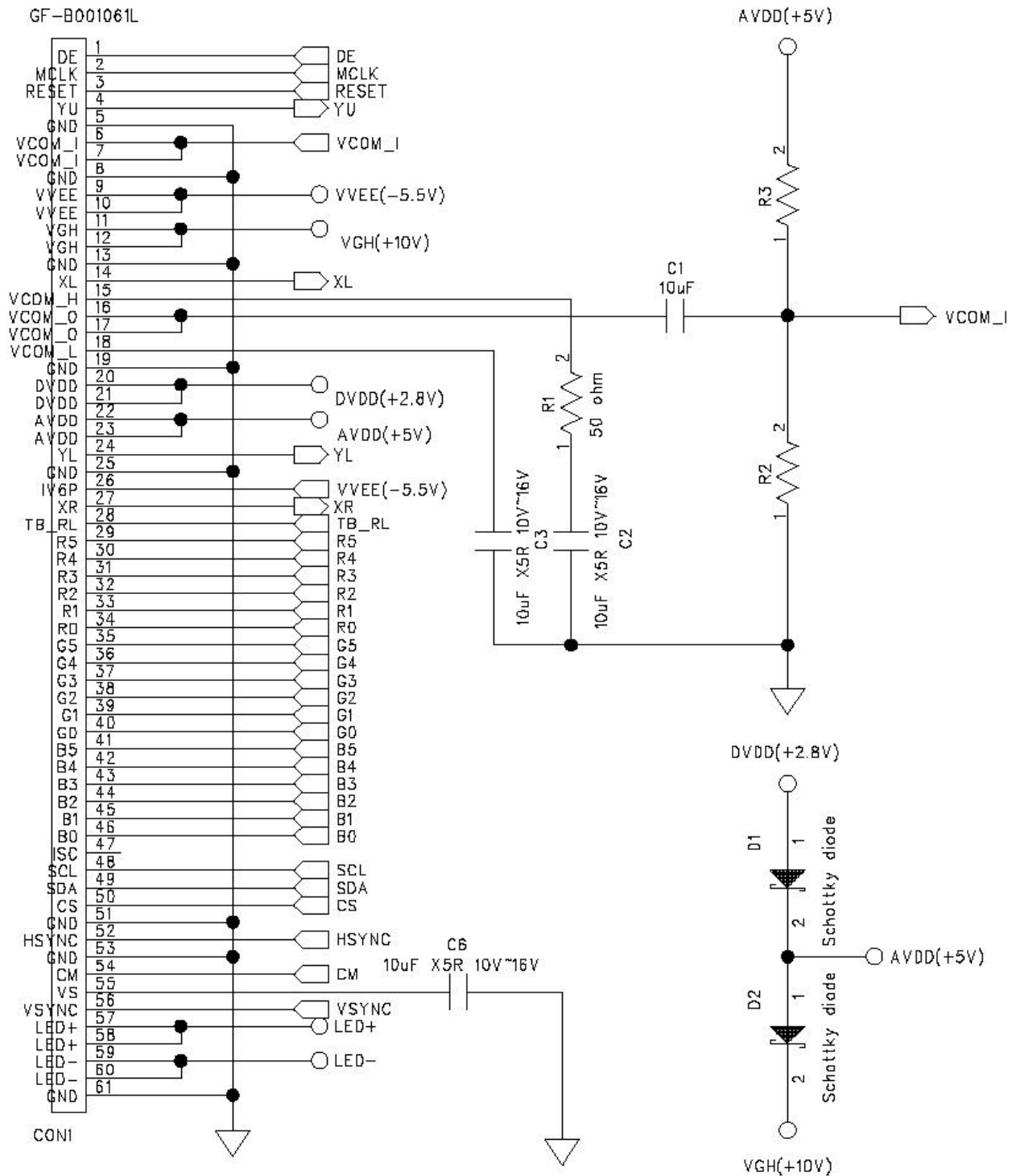

13 Mechanical Drawing

13.1 Module drawing

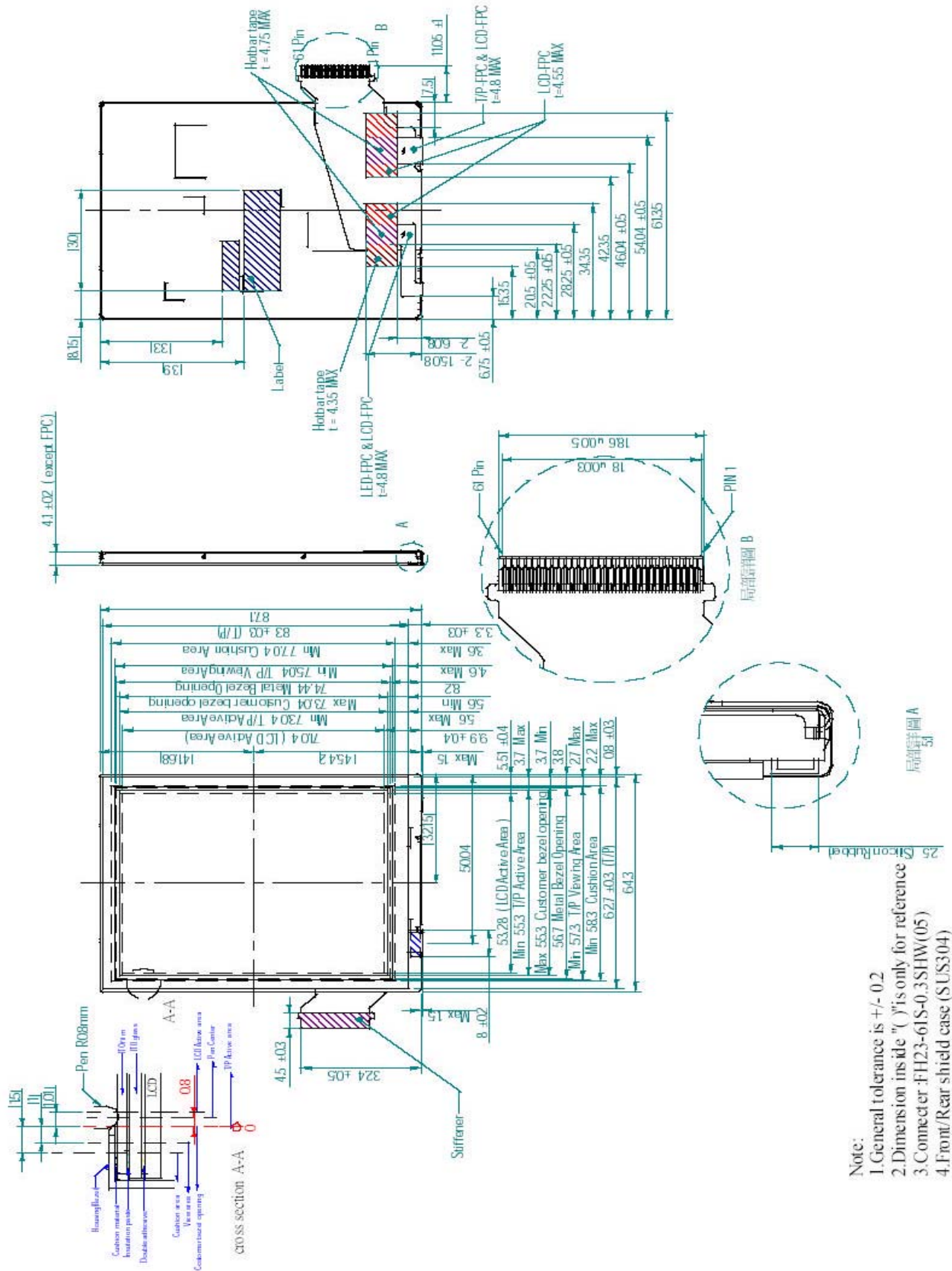

- Note:
1. General tolerance is +/- 0.2
 2. Dimension inside "()" is only for reference
 3. Connector: FH23-61S-0.3SHW(05)
 4. Front/Rear shield case (SUS304)

13.2 Cell panel + FPC drawing

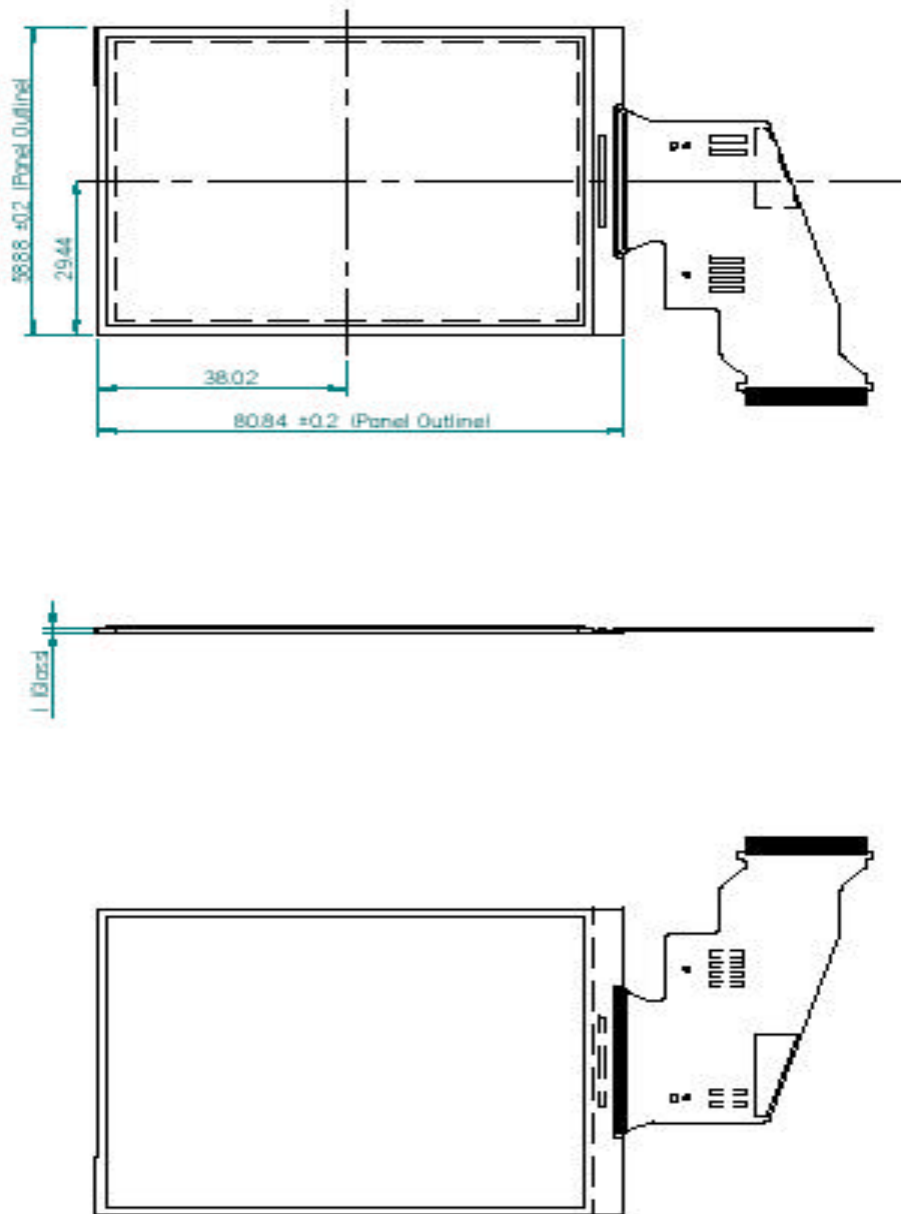

14 Packing Drawing

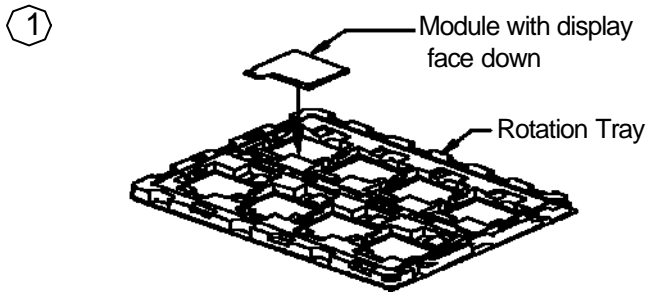

*Module quantity on 1 Tray=8pcs

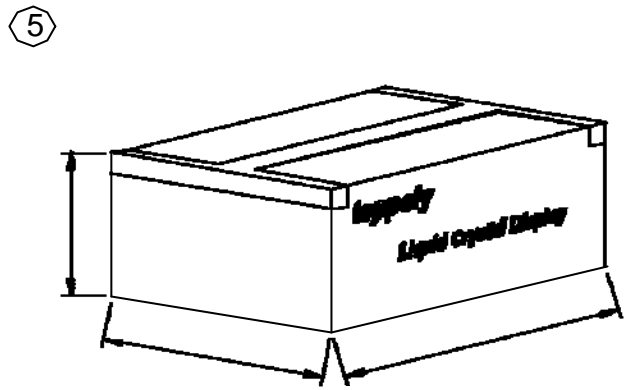
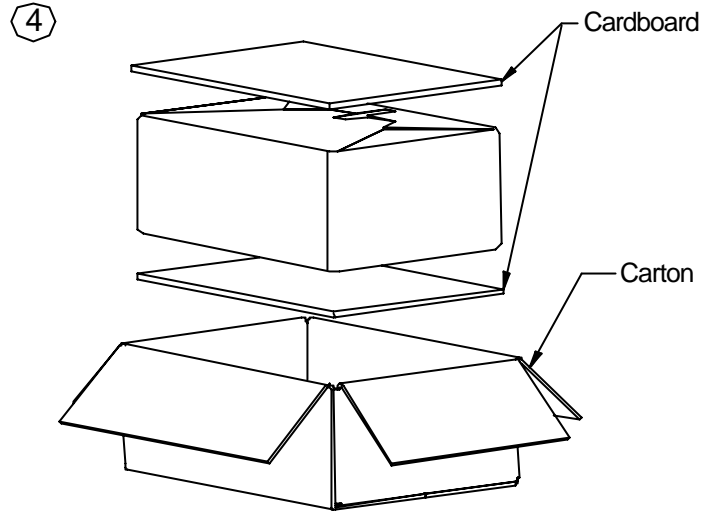
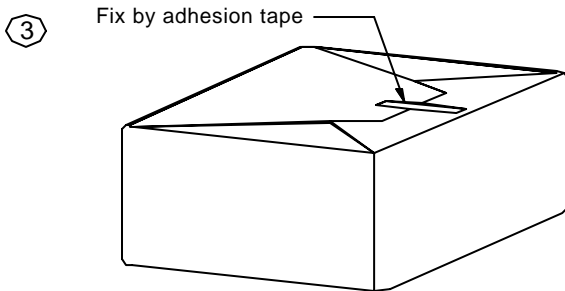
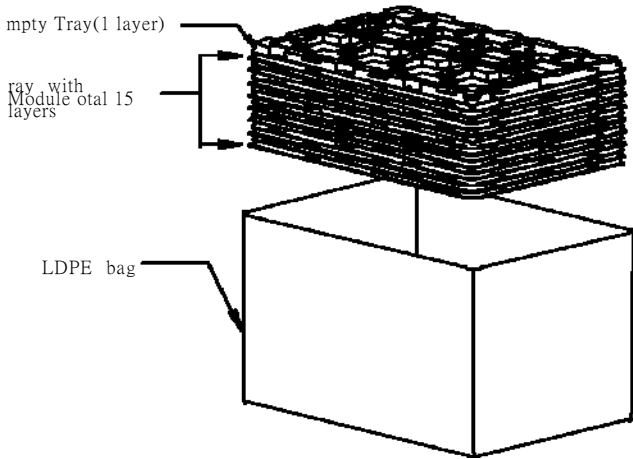
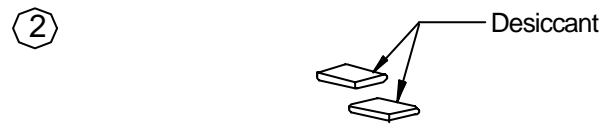

Module quantity in 1 carton=120pcs

TD035STED4 module delivery packing method

14.1 Module packed into tray cavity with display face down.

14.2 Tray stacking with 15 layers and with 1 empty tray above the stacking tray unit.

2 pcs desiccant put above the empty tray.

14.3 Stacking tray unit put into the LDPE bag and fix by adhesive tape.

14.4 Put 1pc cardboard inside the carton bottom, then pack the finished package into the carton.

14.5 Carton sealing with adhesive tape.